

Linear and Gantry Milling in one machine, for X-Axis travel of up to 84 inches (2133.6 mm) and Y-Axis travel of up to 34 inches (863.6 mm).

The Climax LM5200 Milling Machine revolutionizes both the capabilities and functionality of portable mills. Four main features make this one of the best milling machines on the market today:

1. Extremely rigid, modular bed design.
2. Innovative configuration options allow setup for both Linear AND Gantry Milling in one machine.
3. Powerful, precise machining.
4. Reduced Friction Rail Technology.

Rigid, Modular Design

- Unique modular bed design allows shorter bed sections to be combined to fit the length of the work area without losing rigidity.
- Unique bed length section design provides superior rigidity across the entire bed length.
- Connection plates and fasteners optimized to provide the ultimate in rigidity, even when bed is extended by 2 or 3 times the original length.

Flexible Configuration & Operation

- The innovative new design of these Climax Milling Machines allow them to be configured for traditional linear milling, or simply split the rails lengthwise to configure for gantry milling!!
- Electric feeds can be mounted on the X, Y or Z axis.
- Machining capabilities include milling, drilling and even boring.



Powerful, Precise Machining

- Features heavy duty spindle design and a choice of Hydraulic Power Units - a 10 Hp (7.5 kW) HPU allows use of cutter heads of up to 6 inches (152.4 mm) in diameter.
- Milling can be done in any axis, with a milling head that can rotate 360° with an optional swivel plate for optimal spindle flexibility.
- Fast, aggressive milling in horizontal, vertical, or inverted applications.
- Provides reliable, precise milling to meet tight machining tolerances in both linear and gantry mill configurations.

Reduced Friction Rail Technology

- Reduced friction rail system allows extremely smooth, continuous, and non stick-slip travel.
- Precisely machined and aligned rails with advanced lubrication make machining applications smooth and efficient.
- Low friction system reduces maintenance costs and extends product life.
- Precision ball screws in X, Y and Z- axis assemblies allow precise location of milling head.

oficina@vendo.com.pe

SPECIFICATIONS

Operating Ranges:

	Bed		Ram	
	Travel	Length	Travel	Length
LM5200 Model	36 inches (914.4 mm)	48 inches (1219.2 mm)	16 inches (406.4 mm)	26 inches (660.4 mm)
	60 inches (1524.0 mm)	72 inches (1828.8 mm)	34 inches (863.6 mm)	44 inches (1117.6 mm)
	84 inches (2133.6 mm)	96 inches (2438.4 mm)		

US

Metric

Spindle Assembly (Z-Axis):

Milling Head Spindle with #40 Taper

NMTB or CATV or optional HSK

Spindle Drive

Hydraulic, Optional Electric with HSK

Axial Tool Head Travel

4 inches 101.6 mm

Milling Head Gearbox Ratio

1 : 1 1 : 1

Tool Head Position

in 90° increments
(infinite 360° position w/ optional swivel plate)

Gearbox Position Adjustment

180° in 90° increments (3 positions)

Electric Feed

Drive Power

Modified Baldor GP3303 1/2 HP DC gear motor

Gearbox Reduction

20 : 1

Feed Rate

0.5 - 24 in/min 12.7 - 609.6 mm/min

Power Input Requirements

5 amps @ 120V / 2.5 amps @ 230V

Overall Dimensions

Bed (overall length)

Bed Length + 2.5 in.

Bed Length + 63.5 mm

Ram (overall width)

Ram Length + 2.5 in.

Ram Length + 63.5 mm

Height without hand wheel
with hand wheel

18.75 inches
22.0 inches

476.3 mm
558.8 mm

TEST DATA

All test cuts performed with a 10Hp (7.5 KW) HPU and a 7.3 cu. in. (119.6 cu. cm) hydraulic motor in A-36 steel

Orientation	Cutter Diameter	Inserts	Depth of Cut	Width of Cut	Feed Rate
Horizontal Overhang	6 inches (152.4 mm)	7	0.020 inches (0.508 mm)	6 inches (152.4 mm)	14 in/min (355.6 mm/min)
Horizontal Overhang	6 inches (152.4 mm)	7	0.020 inches (0.508 mm)	3 inches (76.2 mm)	14 in/min (355.6 mm/min)
Horizontal Gantry	6 inches (152.4 mm)	7	0.020 inches (0.508 mm)	3 inches (76.2 mm)	12 in/min (304.8 mm/min)
Horizontal Gantry	6 inches (152.4 mm)	7	0.055 inches (1.397 mm)	3 inches (76.2 mm)	1 in/min (25.4 mm/min)
Vertical	4 inches (101.6 mm)	6	0.020 inches (0.508 mm)	3 inches (76.2 mm)	15 in/min (381 mm/min)
Drilling	1.5 inch (38.1 mm) superdrill	n/a	2 inches (50.8 mm)	n/a	Spindle RPM: 250
Boring	2.5 inch (63.5 mm) Criterion Boring Head	n/a	2 inches (50.8 mm)	n/a	Spindle RPM: 425

Flatness (Machine setup & flatness measurements performed with a Hamar laser)					
Configuration	Cutter Diameter	Inserts	Material	Area	Total Flatness
Linear Milling	6 inches (152.4 mm)	7	A-36 Steel Plate	6.0 x 36.0 inches (152.4 x 914.4 mm)	0.0018 inches (0.046 mm)
Gantry Milling	6 inches (152.4 mm)	7	A-36 Steel Plate	6.0 x 36.0 inches (152.4 x 914.4 mm)	0.0015 inches (0.038 mm)

All dimensions should be considered reference. Contact your Climax Representative for precision dimensions. Specifications are subject to change without notice. There are no systems or components on this machine that are capable of producing hazardous EMC, UV or other radiation hazards. The machine does not use lasers nor does it create hazardous materials such as gasses or dust.

TOOL CONFIGURATIONS

Easy Conversion from Linear to Gantry Milling

The Climax LM5200 and LM6200 Milling Machines can be easily reconfigured to perform Linear or Gantry Milling. Below is a step by step overview of the conversion steps from traditional linear milling to gantry milling.

1 Linear Mill set up for overhead milling.

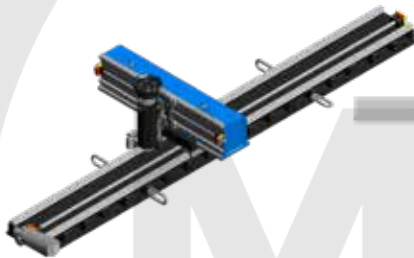

2 Separate main bed and RAM.

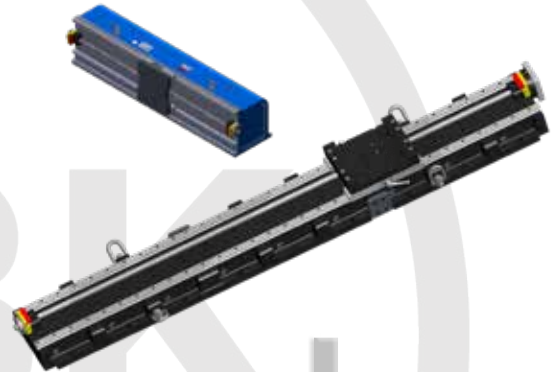

3 Split the bed & saddle pictured above into two separate rails for Gantry Milling as pictured below.



4 Reattach RAM to saddle and rails for a complete Gantry Mill.



All dimensions should be considered reference. Contact your Climax Representative for precision dimensions. Specifications are subject to change without notice. There are no systems or components on this machine that are capable of producing hazardous EMC, UV or other radiation hazards. The machine does not use lasers nor does it create hazardous materials such as gasses or dust.

TOOL CONFIGURATIONS

Configure your LM5200 in 13 steps:

- 1 Select a Base Unit
- 2 Select a Gantry Kit
- 3 Select a RAM Assembly
- 4 Select a Shipping Container
- 5 Select a Milling Head Assembly
- 6 Select Tooling
- 7 Select a Spindle Hydraulic Motor
- 8 Select a Milling Head Swivel Assembly
- 9 Select a Hydraulic Power Unit (HPU)
- 10 Select Hoses and Pendant Cable Assemblies
- 11 Select a Stand Alone Feed Control
- 12 Select a Feed Assembly
- 13 Select a Z-Axis Feed Adapter

To generate the correct part number for the machine you require, simply select the part number needed in each step as appropriate, and contact your Climax representative.

1. Base Unit

- Base Unit, 36 Inch (914.4 mm) Travel, Bed Length 48 Inch (1219.2 mm) **66324**
- Base Unit, 60 Inch (1524.0 mm) Travel, Bed Length 72 Inch (1828.8 mm) **64201**
- Base Unit, 84 Inch (2133.6 mm) Travel, Bed Length 96 Inch (2438.4 mm) **66325**



2. Gantry Kit

- Gantry Kit For 36 Inch (914.4 mm) Travel, Bed Length 48 Inch (1219.2 mm) **64978**
- Gantry Kit For 60 Inch (1524.0 mm) Travel, Bed Length 72 Inch (1828.8 mm) **64624**
- Gantry Kit For 84 Inch (2133.6 mm) Travel, Bed Length 96 Inch (2438.4 mm) **64979**



3. RAM Assembly

- RAM Assembly 16 Inch (406.4 mm) Travel, Length 26 Inch (660.4 mm) **72642**
- RAM Assembly 34 Inch (863.6 mm) Travel, Length 44 Inch (1117.6 mm) **72643**
- RAM Assembly 16 Inch (406.4 mm) Travel, Length 26 Inch (660.4 mm) & RAM Assembly 34 Inch (863.6 mm) Travel, Length 44 Inch (1117.6 mm) **67652**

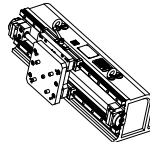

4. Shipping Container

- Wooden Crate for 36 In (914.4 mm) Travel Bed **65237**
- Metal Container for 36 In (914.4 mm) Travel Bed **65397**
- Wooden Crate for 60 In (1524.0 mm) Travel Bed **65239**
- Metal Container for 60 In (1524.0 mm) Travel Bed **65398**
- Wooden Crate for 84 In (2133.6 mm) Travel Bed **65240**
- Metal Container for 84 In (2133.6 mm) Travel Bed **65399**

5. Milling Head Assembly

- Inch #40 Taper NMTB **62399**
- Inch #40 Taper CATV **62732**
- Metric #40 Taper NMTB **62654**
- Metric #40 Taper CATV **62733**
- Hydraulic #40 HSK **65262**
- 120V Electric #40 HSK (Motor Included) **77878**
- 230V Electric #40 HSK (Motor Included) **77875**
- Pneumatic Right Angle #40 HSK **68455**
- Pneumatic Direct Drive #40 HSK **68584**

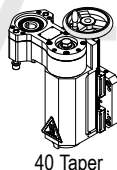

40 Taper

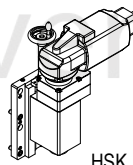

HSK

6. Tooling (for inch milling head assy only)

- #40 Taper**
- #40, 4 Inch (101.6 mm) Face Mill with Inserts **47380**
- #40, 5 Inch (127.0 mm) Face Mill with Inserts **47381**
- #40, 6 Inch (145.4 mm) Face Mill with Inserts **47382**
- Carbide Inserts **47229**

- HSK #40A Hydraulic, 120V and 230V**
- #40A, 3 Inch (76.2 mm) HSK Face Mill w/ Inserts **64984**
- Collet Holder ER-32 #40A HSK Taper, 0.08 - 0.81 Inch (2.0 - 20.6 mm) **64985**
- Carbide Inserts **47229**

Collet Tooling

- HSK 40A Hydraulic, 120V and 230V**
- Collet Inch ER-32, 3/4 Inch **64986**
- Collet Metric ER-32, 20 mm **66344**
- Collet Set Inch ER-32, 1/8 - 13/16, 1/16 Increments **66345**
- Collet Set Metric ER-32, 3 - 20 mm, 1mm Increments **66346**
- Cutter Fly 2-1/2 Inch Diameter Head x 3/4 Inch Shank **20713**
- Cutter Fly 2-1/4 Inch (57.15 mm) Dia. Head x 20 mm Shank **31625**

7. Spindle Hyd. Motors Assembly

Milling Head Assembly	Motor Displacement		Max Spindle Speed		Hydraulic Motor PN	
	in ³	cm ³	@ 50 Hz Mains Power	@ 60 Hz Mains Power	60 Series	ISO 16028
40 Taper	3.6	59.0	490	591	62627	84224
	5.7	93.4	292	353	62628	84225
	7.3	119.6	228	275	62629	84226
	8.8	144.2	183	221	62630	84227
HSK 40A	1.21	19.8	873	1009	65094	79701
	1.93	31.6	502	606	65095	79699
	3.00	49.2	306	369	65096	83963

Minimum speed is 20% of the maximum speed

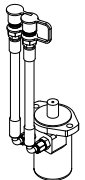

8. Milling Head Swivel Assembly

- Milling Head Swivel Plate Assembly **66217**



9. Hydraulic Power Unit

HP1000, 208 - 230 Volts				
Cordset/hose length		Quick Connect Style		PN
Feet	Meters	60 Series QD	ISO 16028 CE	
20	6	✓		85815
50	15	✓		90947
100	30	✓		90948
20	6		✓	90962
50	15		✓	90963
100	30		✓	90964

NOTE: Drawings are for reference only, are not to scale, and may not represent actual product.

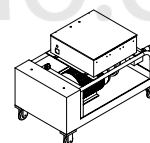

TOOL CONFIGURATIONS

Hydraulic Power Unit (continued)

HP1000, 380 - 415 Volts				
Cordset/hose length		Quick Connect Style		PN
Feet	Meters	60 Series QD	ISO 16028 CE	
20	6	✓		85789
50	15	✓		90949
100	30	✓		90950
20	6		✓	90965
50	15		✓	90966
100	30		✓	90967

HP1000, 460 Volts				
Cordset/hose length		Quick Connect Style		PN
Feet	Meters	60 Series QD	ISO 16028 CE	
20	6	✓		85785
50	15	✓		90951
100	30	✓		90952
20	6		✓	90968
50	15		✓	90969
100	30		✓	90970

HP1000, 575 Volts				
Cordset/hose length		Quick Connect Style		PN
Feet	Meters	60 Series QD	ISO 16028 CE	
20	6	✓		89633
50	15	✓		90953
100	30	✓		90954
20	6		✓	90973
50	15		✓	90974
100	30		✓	90975

10. Stand Alone Feed Control

(Stand Alone Control Panel & Pendant with Cables)

NOTE: Not needed if using a CLIMAX Hydraulic Power Unit

Tooling	Voltage	Cable Length	PN
40 Taper	120V	20 ft (609.6 cm)	53398
		50 ft (1524.0 cm)	53399
		100 ft (3048.0 cm)	53400
	230V	20 ft (609.6 cm)	53401
		50 ft (1524.0 cm)	53402
		100 ft (3048.0 cm)	53403

11. Electric Feed Assembly

NOTE: 230V Feeds not for use with Climax Hydraulic Power Units

Voltage	Cable Length	PN
120V	20 ft (609.6 cm)	64684
	50 ft (1524.0 cm)	66310
	100 ft (3048.0 cm)	66311
230V	20 ft (609.6 cm)	64743
	50 ft (1524.0 cm)	66312
	100 ft (3048.0 cm)	66313

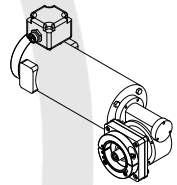

12. Z-Axis Feed Adapter

Z-Axis Feed Adapter Kit - I Axis 40 Taper

64856

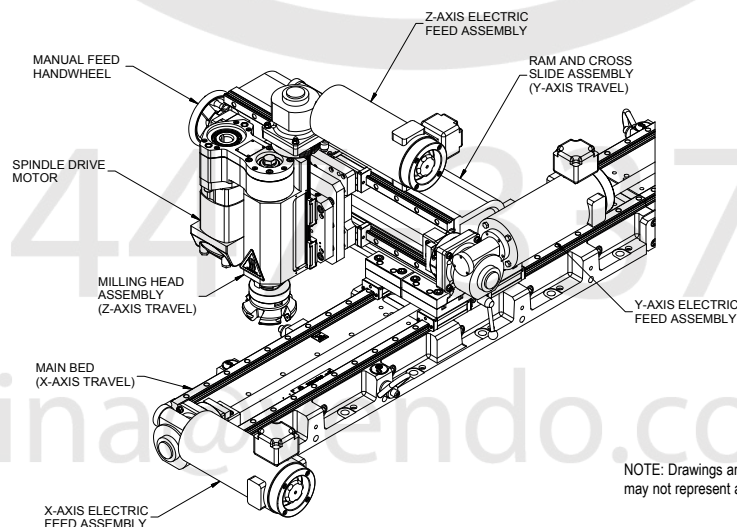

NOTE: Drawings are for reference only, are not to scale, and may not represent actual product.

OPERATIONAL DIMENSIONS

Dimensions in Inch (mm)

Milling Area Dimensions - LINEAR MILLING

12" (304.8 mm) with 16" (406.4 mm) Travel RAM
 **12" (304.8 mm) with 34" (863.6 mm) Travel RAM

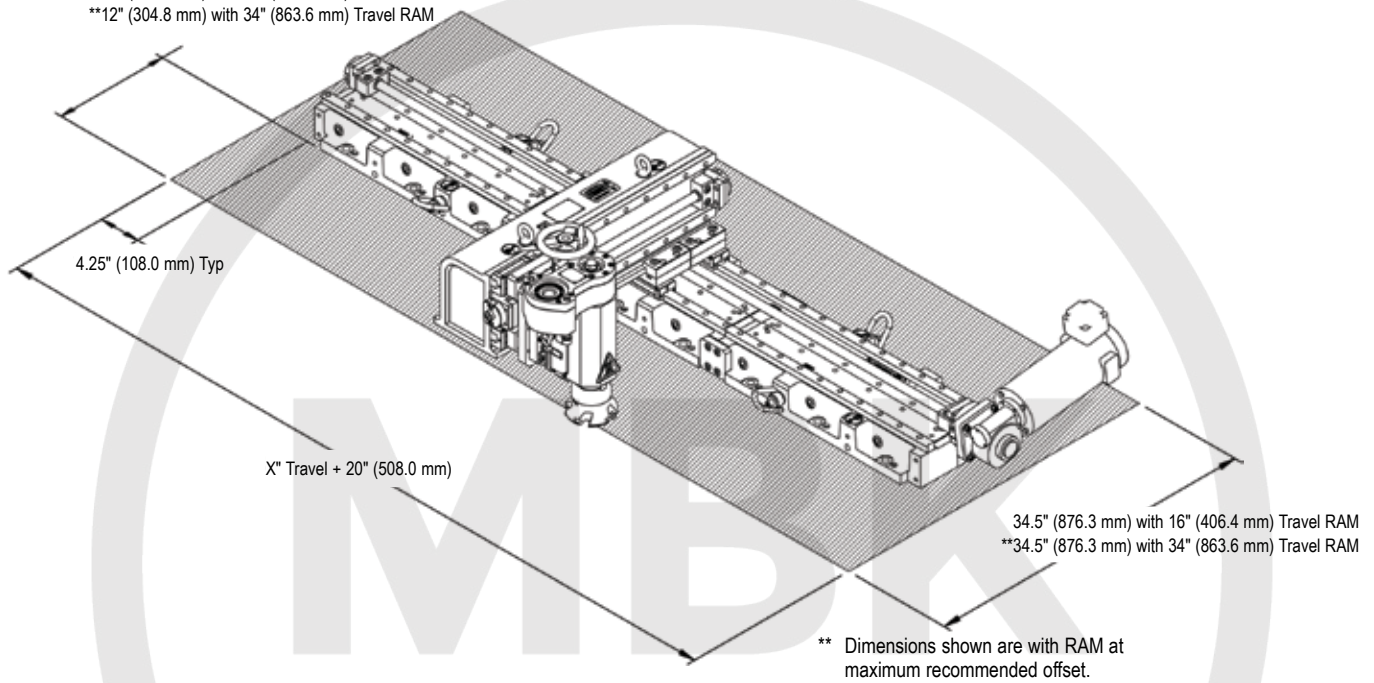

Milling Area Dimensions - GANTRY MILLING

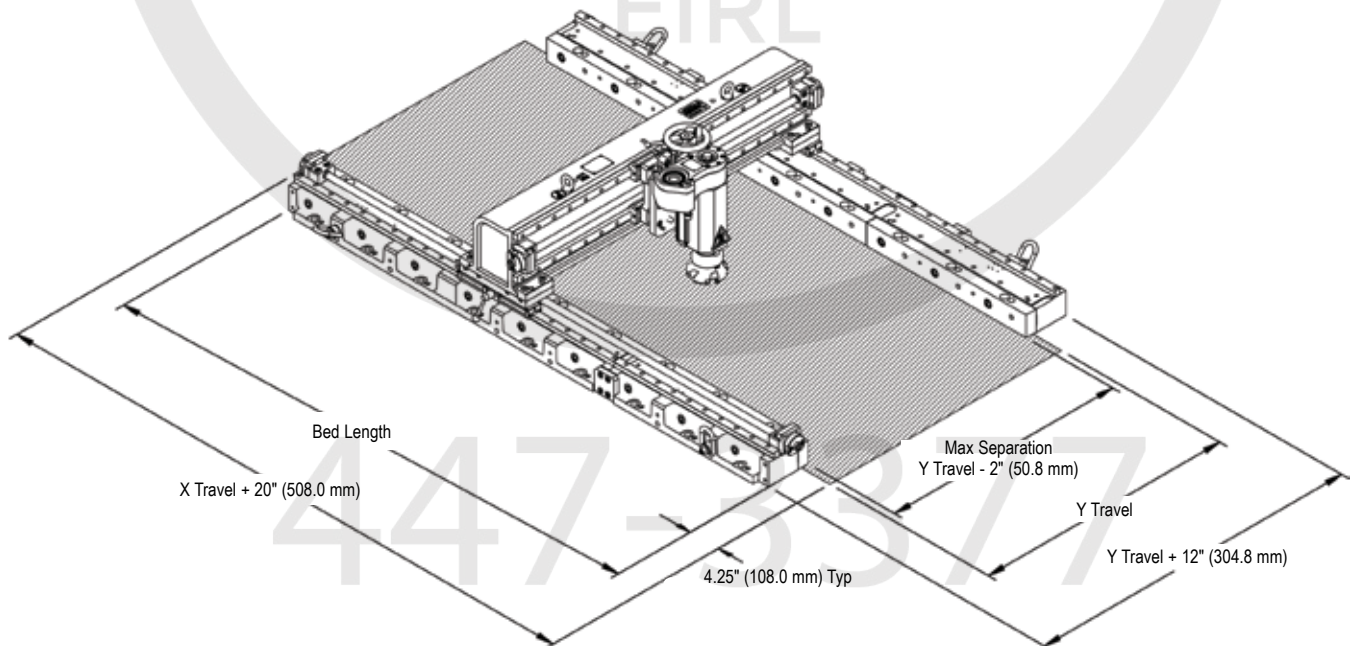

oficina@vendo.com.pe

OPERATIONAL DIMENSIONS

Dimensions in Inch (mm)

Overhead View - Standard Offset

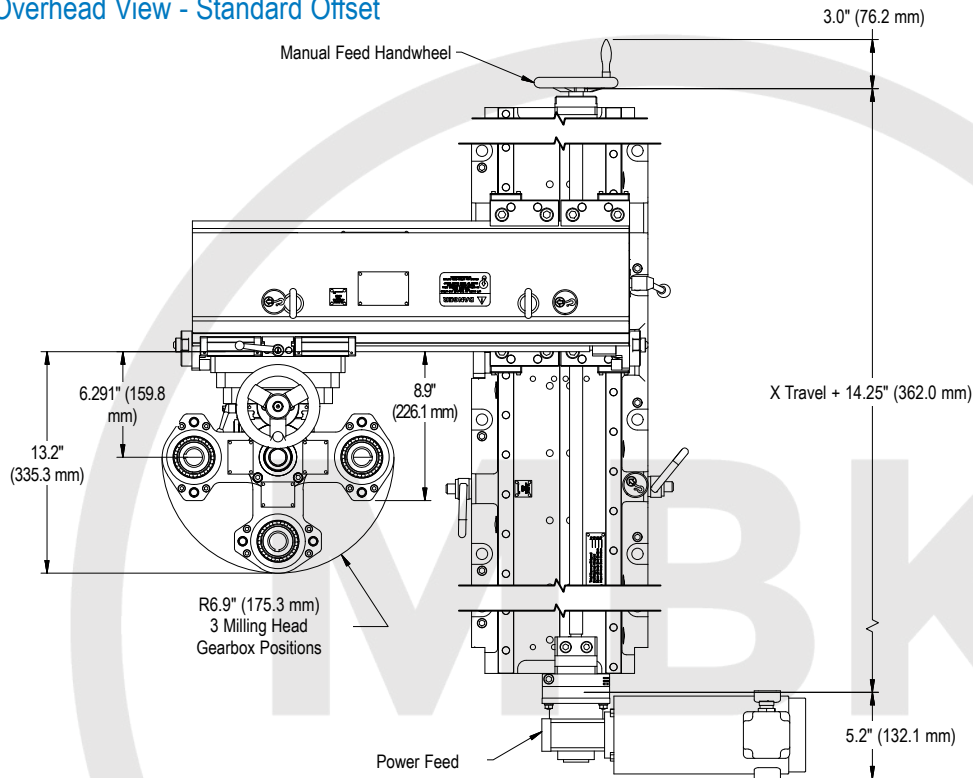

Overhead View - RAM at Maximum Recommended Offset

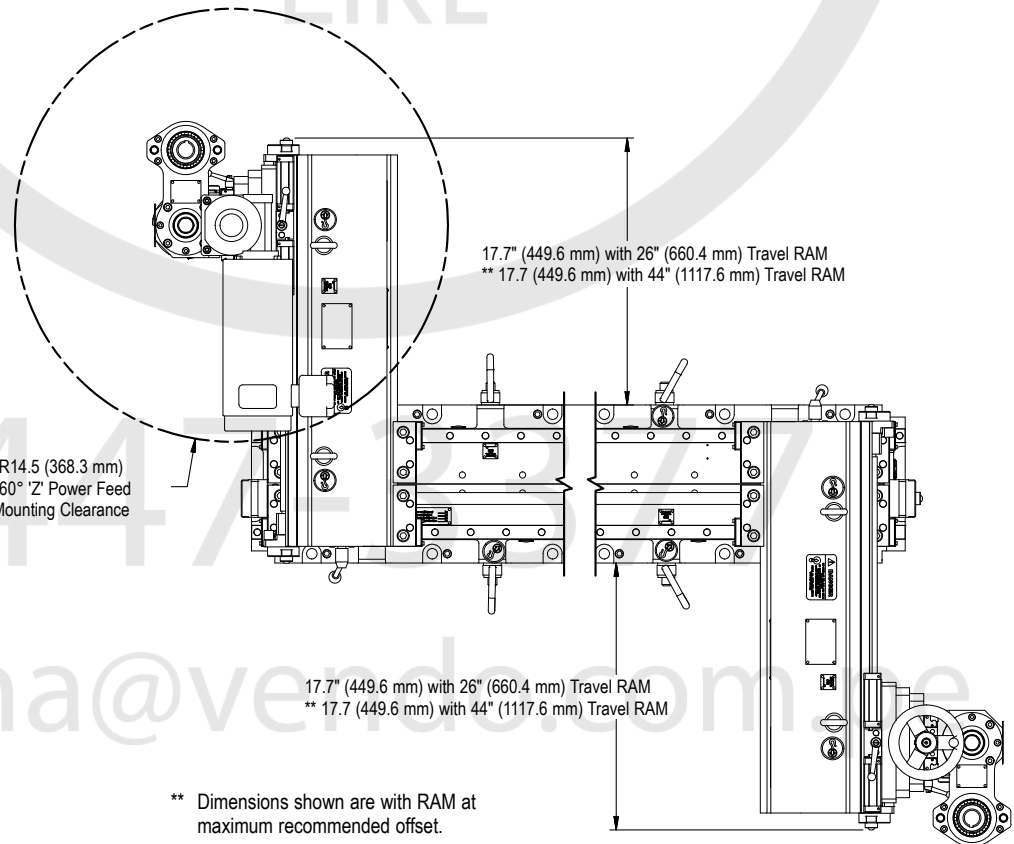

** Dimensions shown are with RAM at maximum recommended offset.

OPERATIONAL DIMENSIONS

Dimensions in Inch (mm)

Inverted Milling Area

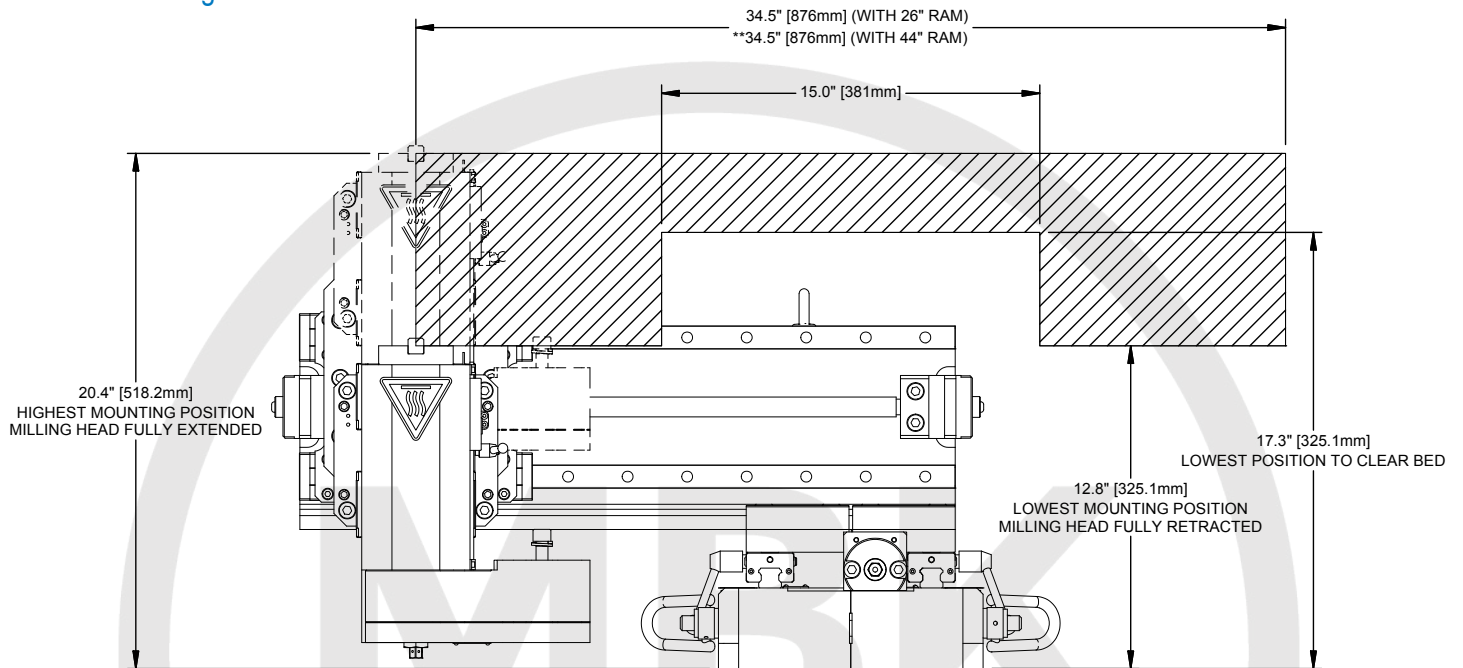

Side Milling

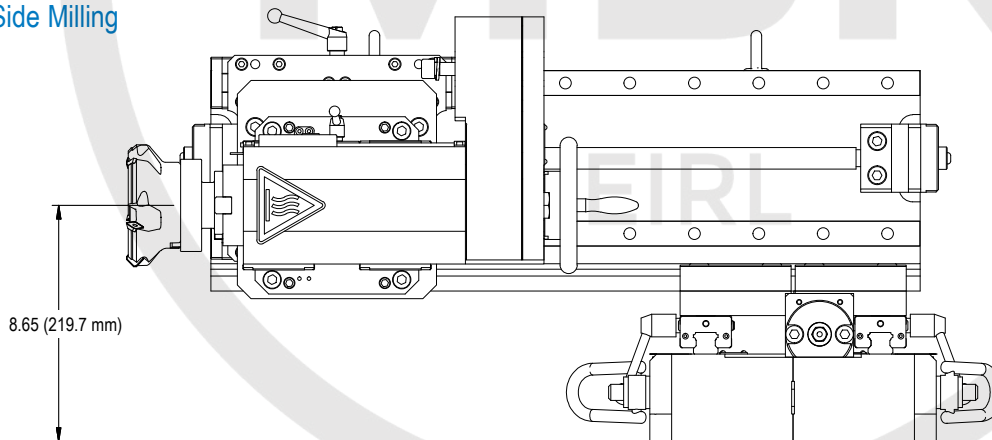

Example of side milling. (No vertical movement in this configuration.)

Spindle Travel

Gearbox can be rotated in 90° increments; motor may be mounted on or under the gearbox.

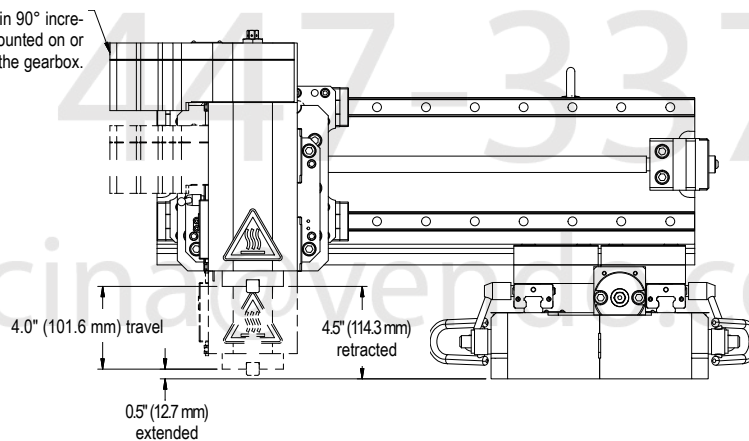

OPERATIONAL DIMENSIONS

End View

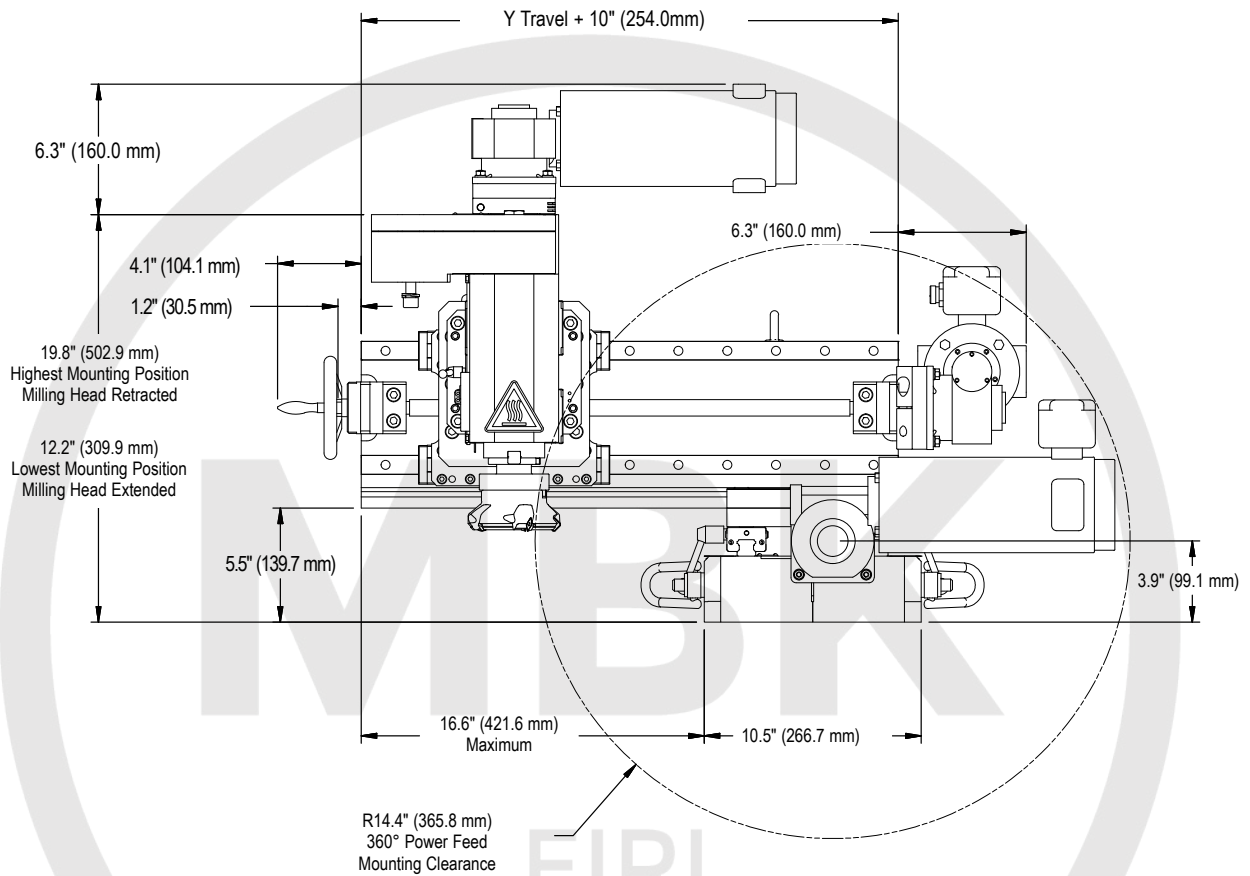

Bottom View

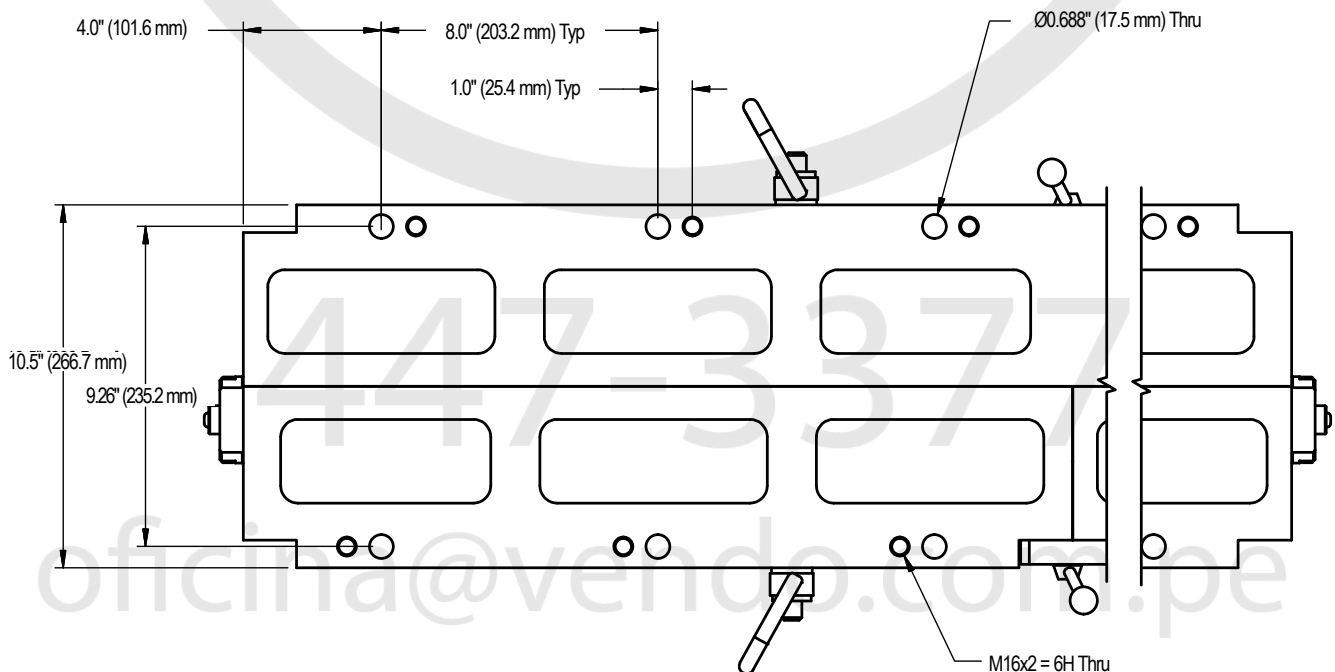

OPERATIONAL DIMENSIONS

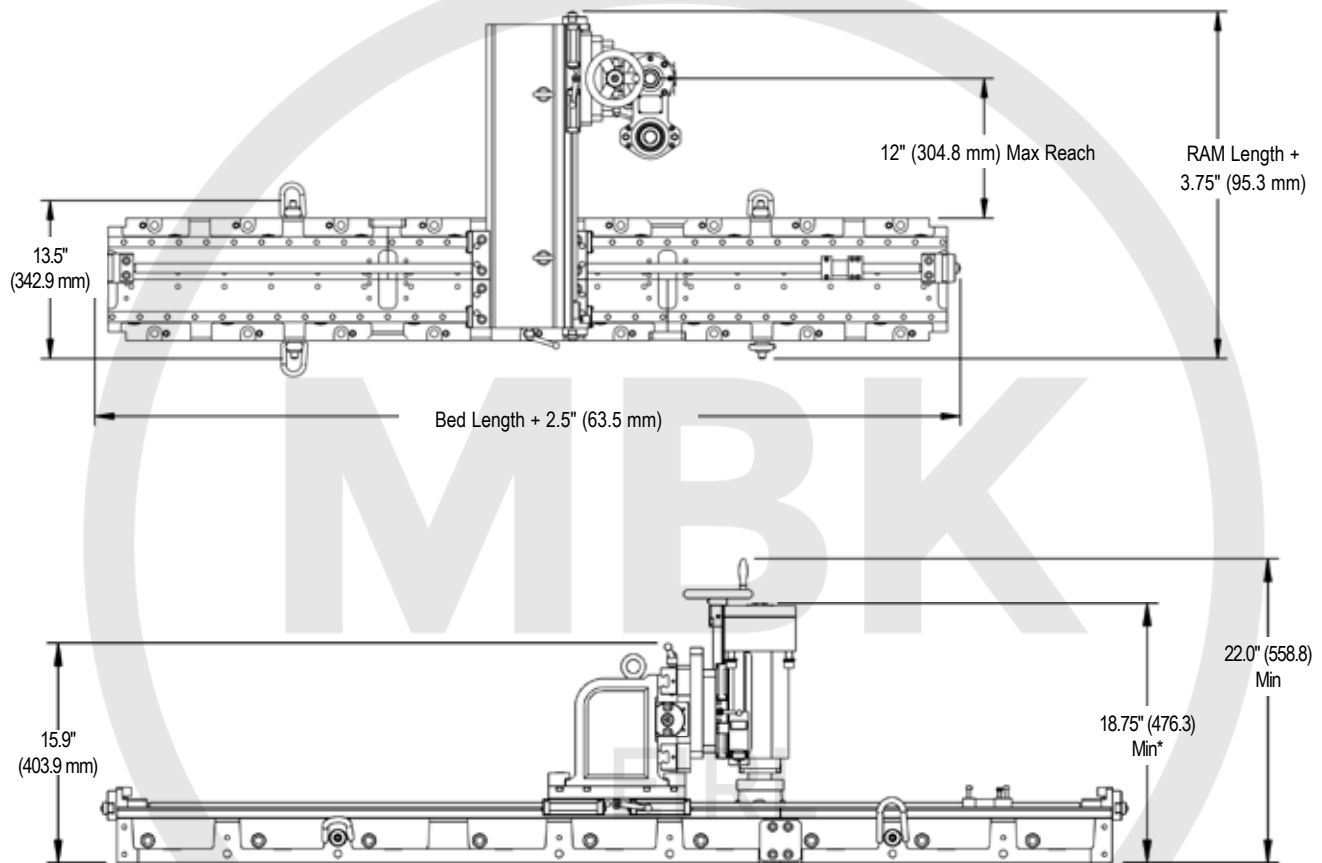

* Minimum dimension to allow milling head with cutter to clear mounting surface

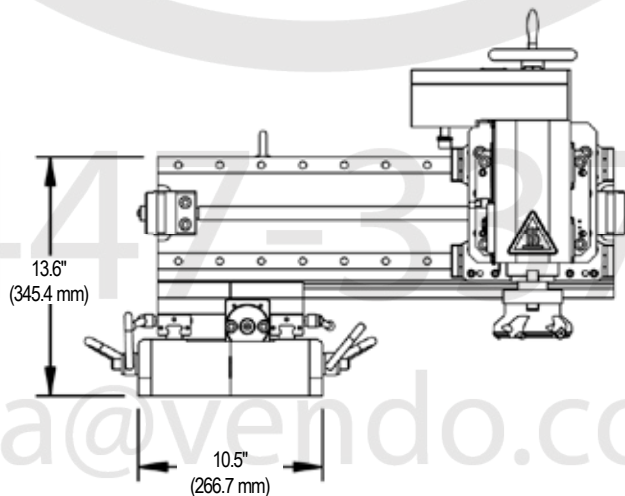

CLIMAX Training Facilities

CLIMAX has been teaching the fundamentals and finer points of portable machine tool operation for more than 50 years.

Whether it's a regularly scheduled course at one of our seven Global Training Centers or a custom curriculum conducted with your team, at your facility, your technicians will benefit from courses developed by the most experienced and respected professionals in the business.

Regularly scheduled courses in basic and advanced tool operation are available. A vast majority of every program is devoted to hands-on activities, skills development, and OEM Certification covering the following subject matters: operator safety, tool component review, setup and mounting, standard and advanced operational techniques, overview of cutting tools and recommended usage, and maintenance procedures.



Training is available at the following seven Global Training Centers:

- Portland, Oregon
- Houston, Texas
- Gonzales, Louisiana
- Wadsworth, Ohio
- Manchester, United Kingdom
- Düren, Germany
- Dubai, United Arab Emirates

Call us today to schedule training for your team!



CLIMAX GLOBAL LOCATIONS



Call CLIMAX for:

Rentals

With 21 worldwide rental depot locations, you are never far away from a CLIMAX tool.

On-site Training

Need some refresher courses in setting up and operating your CLIMAX machine tool?

Custom Projects

CLIMAX has been solving complicated machining, welding and valve testing problems for our customers since 1964.

Connect with us:



World Headquarters | Factory

Address: 2712 E. 2nd St, Newberg, Oregon 97132
Tel: +1 503 538 2185
Fax: +1 503 538 7600
Email: info@cpmt.com

Regional Office | H&S TOOL Factory

Address: 715 Weber Dr., Wadsworth, Ohio 44281
Tel: +1 330 336 4550
Fax: +1 503 538 7600
Email: info@hstool.com

Asia Pacific

Address: 308 Tanglin Rd #02-01, Singapore 247974
Tel: +65 6801 0662
Fax: +65 6801 0699
Email: ClimaxAsia@cpmt.com

European

Address: Am Langen Graben 8, 52353 Düren, Germany
Tel: (+49) (0) 2421 9177 0
Fax: (+49) (0) 2421 9177 29
Email: ClimaxEurope@cpmt.com

Middle East

Address: Warehouse #5, Plot: 369 272, Um Sequim Road, Dubai, UAE
Tel: +971 4 321 0328
Email: ClimaxUAE@cpmt.com

United Kingdom

Address: Unit 7 Castlehill Industrial Estate, Bredbury Industrial Park, Horsfield Way, Stockport SK6 2SU
Tel: +44 (0) 161 406 1720
Email: info@cpmt.com